

GAT NET.Lock 7000 Electronic Locker Locks

Application

The GAT NET.Lock 7000 is the ideal solution for the convenient electronic locking of wardrobe lockers in fitness clubs, baths, golf resorts, and other individual company applications. The identification at the GAT NET.Lock 7000 is carried out via contactless RFID data carriers (Radio Frequency Identification).

The GAT NET.Lock 7000 is suitable for different locker door materials (wood, HPL, fully synthetic materials, glass or even metal doors when using the booster unit) and is useable for doors that open to the left or right. The various operating modes enable the flexible use of these locks.

Slave controllers GAT NET.Controller S 7000 are used for communication and control of the GAT NET.Lock 7000. They are available for several RFID technologies (LEGIC® and MIFARE™ + ISO 15693).



GAT NET.Lock 7000

Functional description

The electronic locks GAT NET.Lock 7000 are connected to slave controllers GAT NET.Controller S 7000. Up to 24 locks can be connected to one slave controller. Each slave controller in a system is further connected via serial RS 485 interface to a master controller GAT NET.Controller M 7000. To use a locker, the user presses the locker door shut and holds his data carrier up to the reader centre of the GAT NET.Lock 7000. The lock reads the data carrier information and sends the information to the slave controller. Depending on the operation type (Online/Offline) the user data are checked by the controller autonomously or by a PC software on the server. The controller or server response will then signal the lock to lock or unlock the locker door. The locking status of the door is signalled by the lock's status LED.

Highlights

- Up to 24 GAT NET.Lock 7000 per GAT NET.Controller S 7000
- Different operation modes possible
- Reliable data transmission between the reader and data carrier
- For left and right doors and various types of locker doors
- Self-adjustment of the RFID field
- LED status display (multi-colour)
- Motor driven locking/unlocking for highest reliability
- Different bolt sets with integrated RFID booster
- Easy and secure bolt mounting
- Front plate for metallic doors (for labelling with locker number and logo etc.), individual designs possible

Accessories

Description	PartNo.
GAT NET.Lock Basic Set B	369131
GAT NET.Lock Basic Set F	369232
GAT NET.Lock Basic Set ISO	369333
The sets include master cards	
GAT NET.Lock BoltSet 7100	369535
Door shackle carrier and booster for non-metallic doors	
GAT NET.Lock BoltSet 7200	532123
Door shackle carrier and booster for metallic doors	

Order information

Description	PartNo.
GAT NET.Lock 7000	368534
Electronic RFID locker lock	

Accessories

Description	PartNo.
GAT NET.Controller M 7000	253224
Master controller for the slave controllers GAT NET. Controller S 7000	
GAT NET.Controller S 7000 B	253325
Slave control unit for the electronic locker locks GAT NET. Lock 7000, with integrated LEGIC® reader.	
GAT NET.Controller S 7000 F/ISO	253426
Slave control unit for the electronic locker locks GAT NET. Lock 7000, with integrated MIFARE™/ISO 15693 reader.	
GAT NET.Lock Tool 7000	533831
Center punch gage for bolt mounting	
GAT NET.Lock Connector	442123
Connector for connection cables	
GAT NET.Lock Cable 4m	321826
Cable for connection of the GAT NET.Lock 7000, length 4 m, 4-pin plug on both sides	
GAT NET.Lock Label GEA right	679034
GAT NET.Lock Label GEA NUM right	679236
Self-adhesive door label in GANTNER design, for right-hinged doors, without/with locker number	
GAT NET.Lock Label GEA left	370022
GAT NET.Lock Label GEA NUM left	679135
Self-adhesive door label in GANTNER design, for left-hinged doors, without/with locker number	

Technical Data

Nominal voltage Ubc:	5 V
Power supply:	Via connection cable from the slave controller
Aver. power consumption:	60 mW
Reader types:	
GAT NET.Controller S 7000	
- B:	LEGIC®
- F/ISO:	MIFARE™ + ISO 15693
Retaining force:	Min. 1,500 N
Force on inner side of the door:	Max. 100 N
User guidance	Multi-Colour status LED
Interface:	One-Wire (special cable for supply, data and RF signal)

Number locks per slave cont.:	24
Connectors:	MOLEX, type Micro-Fit 3.0™
Housing material:	Plastic (PC)
Door width:	min. 230 mm
Dimensions:	110 x 100 x 25 mm
Permitted ambient temperature:	0 to +60°C
Protection type:	IP 52
Protection class:	III
Weight:	Approx 160 g
Environment class based on VDS 2110:	II (conditions in indoor areas)

Dimensions

GAT NET.Lock 7000

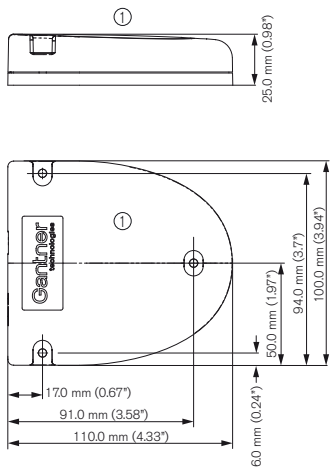

GAT NET.Lock BoltSet 7100

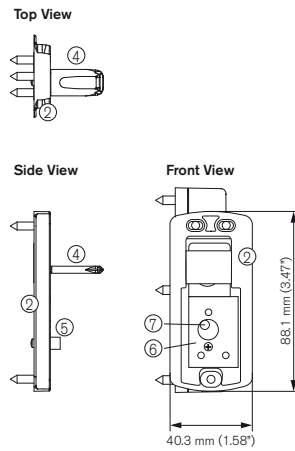

GAT NET.Lock BoltSet 7200

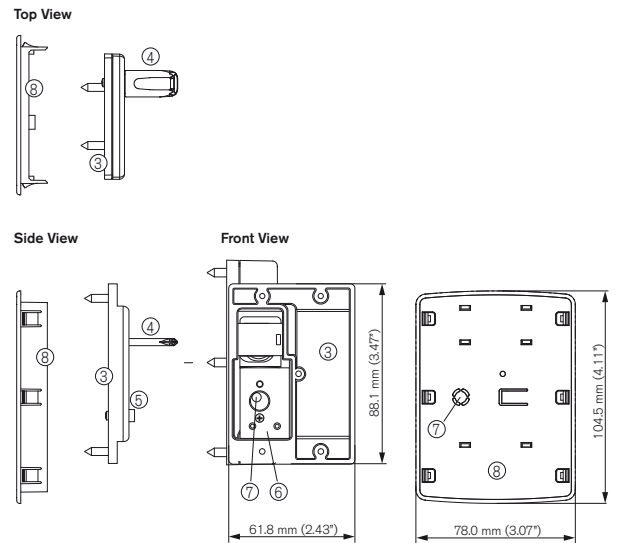

1. GAT NET.Lock 7000
2. GAT NET.Lock Bolt Set 7100 (for non-metal doors)
3. GAT NET.Lock Bolt Set 7200 (for metal doors)
4. Door shackle
5. Door contact
6. Booster
7. Status LED
8. Label Carrier

Typical application

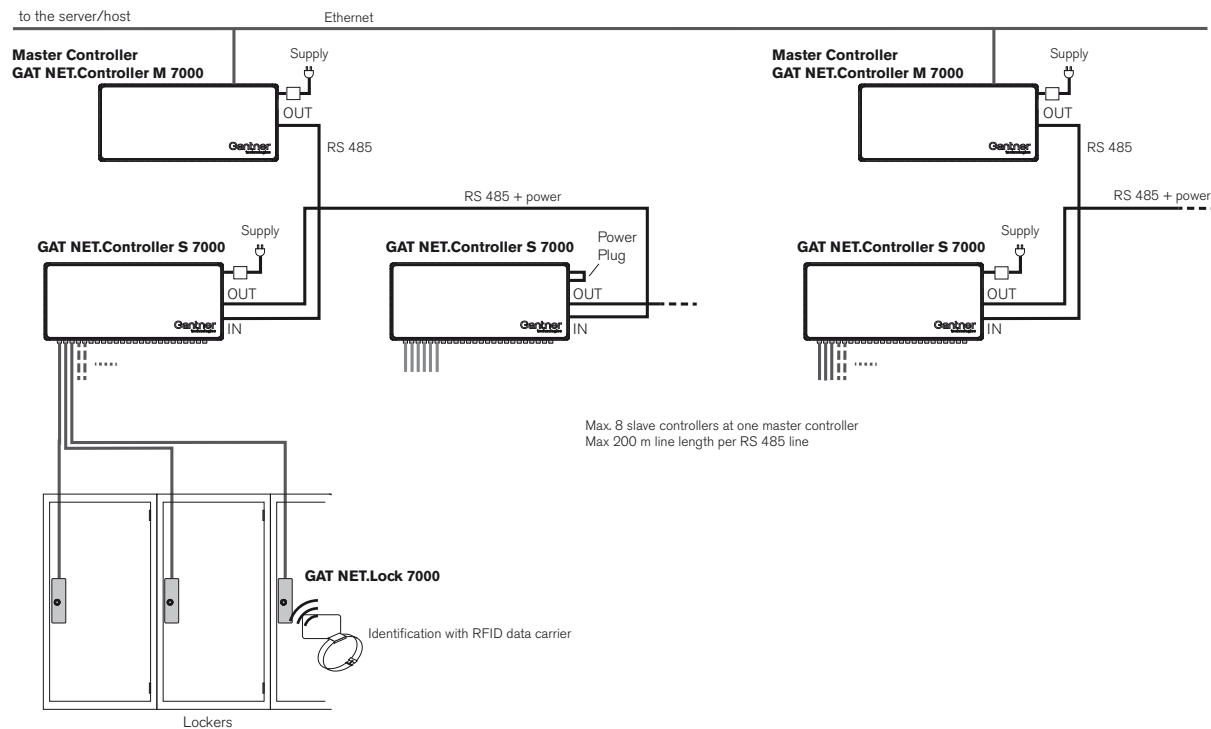

Mounting and Installation Instructions

The GAT NET.Lock 7000 is mounted with 3 screws (1) on the inside of the locker. The bolt set with the door shackle is mounted on the inside of the locker door. At non-metallic doors only a drilling for the LED is required. At metallic doors a cut-out must be made in the door, where the bolt set and label carrier will be mounted.

Door status contact

The GAT NET.Lock 7000 has a contact which gets activated by the door contact (5) at the bolt set as soon as the locker door is closed. This allows to determine the open/close state of the door. To guarantee the correct functionality of the GAT NET.Lock 7000 it is important that this contact is clean and not damaged.

Door width

The minimum allowed door width (measured from the door shackle to the hinge) is 230 mm. If the door is narrower than this measure, the door shackle would hit the locker when the door is being closed.

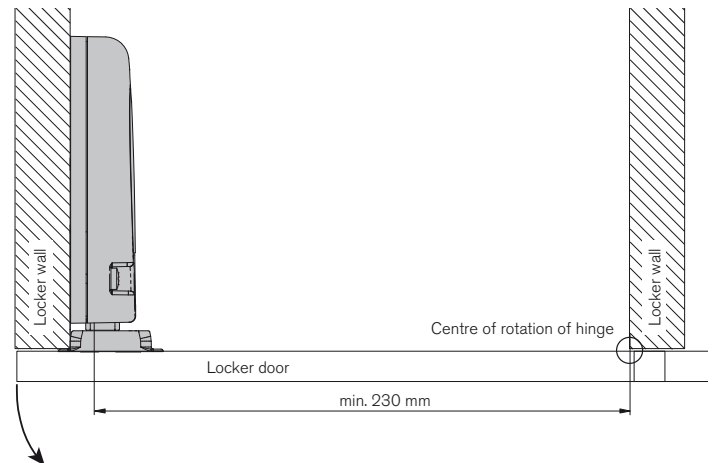

Mounting on Non-Metallic Doors

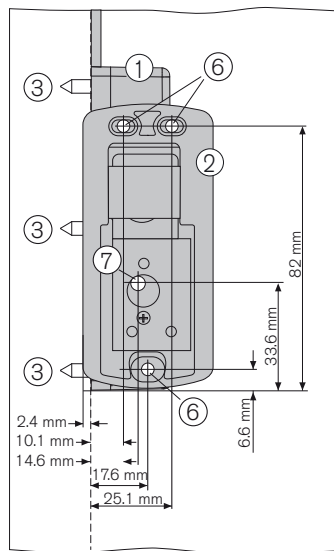
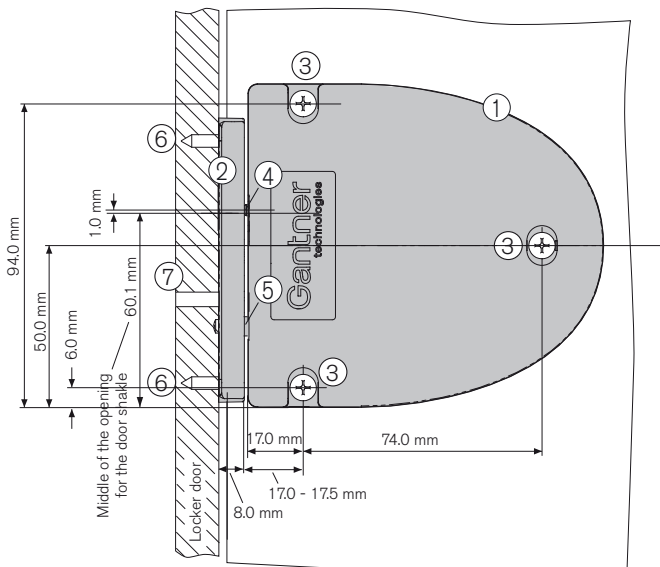

1. GAT NET.Lock 7000
2. GAT NET.Lock Bolt Set 7100
3. Mounting screws for GAT NET.Lock 7000
4. Door shackle
5. Door contact
6. Mounting screws for bolt set
7. LED (hole in locker door)

Installation measures for GAT NET.Lock 7000 and Bolt Set

- During the mounting, please pay particular attention to the following points:
- When the door is pressed shut, the gap between the bolt set (2) and the front of the GAT NET.Lock 7000 must not exceed 0.5 mm. Ideally the bolt set should touch the front of the lock.
 - The middle of the door shackle (4) must be 1 mm higher than the middle of the door shackle opening in the GAT NET.Lock 7000. This ensures the door's ability to close even if the door position is modified 3 mm downwards or 1 mm upwards (tolerance ± 2 mm).

Mounting procedure

Note: Before mounting all locks of the locker system a test installation of at least one lock and final function check must be performed like described below. Only if the tests are successful the rest of the locks may be mounted in the same way.

1. Drill the three holes (3) for the GAT NET.Lock 7000 into the locker wall.
2. Plug-in the connection cable (see page 6).

3. Mount the GAT NET.Lock 7000 with three screws (3) on the inside locker wall.

Note: Use the right screws according to the type of locker material.



Attention: The max. allowed tightening torque of the screws is 2 Nm.

4. Drill the three holes (6) for mounting the GAT NET.Lock Bolt Set 7100.
5. Drill a hole for the LED display in the locker door (7). The recommended hole diameter is 10 mm.

Note: A front label can be used to cover the LED hole. If the customer designs the label he must pay attention that a transparent field for the LED light should be placed on the label.

6. Mount the bolt set onto the locker door by using three screws.
- Note:** Use the right type and length of the screws according to the type of locker material.



Attention: The max. allowed tightening torque of the screws is 2 Nm.

7. Close the locker door to test, if the door can be closed easily and the door shackle inserts into the opening in the GAT NET.Lock 7000.

Mounting on Metallic Doors

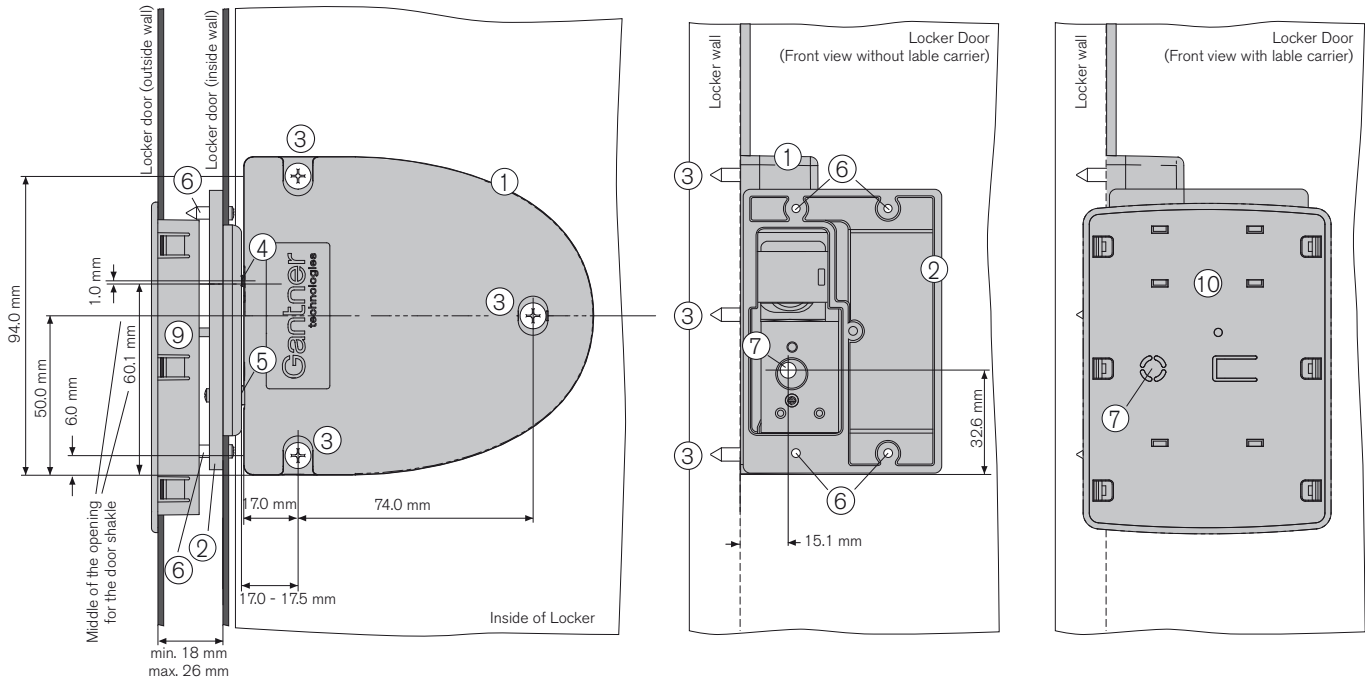

Installation measures for GAT NET.Lock 7000 and Bolt Set

During the mounting, please pay particular attention to the following points:

- The door thickness must be between 18 and 26 mm (see figure).
- When the door is pressed shut, the gap between the bolt set (2) and the front of the GAT NET.Lock 7000 must not be exceeded 0.5 mm. Ideally the bolt set should touch the front of the lock.
- The middle of the door shackle (4) must be 1 mm higher than the middle of the door shackle opening in the GAT NET.Lock 7000. This ensures the door's ability to close even if the door position is modified 3 mm downwards or 1 mm upwards (tolerance ± 2 mm).

1. GAT NET.Lock 7000
2. GAT NET.Lock Bolt Set 7200
3. Mounting screws for GAT NET.Lock 7000
4. Door shackle
5. Door contact
6. Mounting screws for bolt set
7. LED position
8. Cut-out for GAT NET.Lock Bolt Set 7200
9. Cut-out for label carrier
10. Label carrier

Cut-outs in the Locker Door

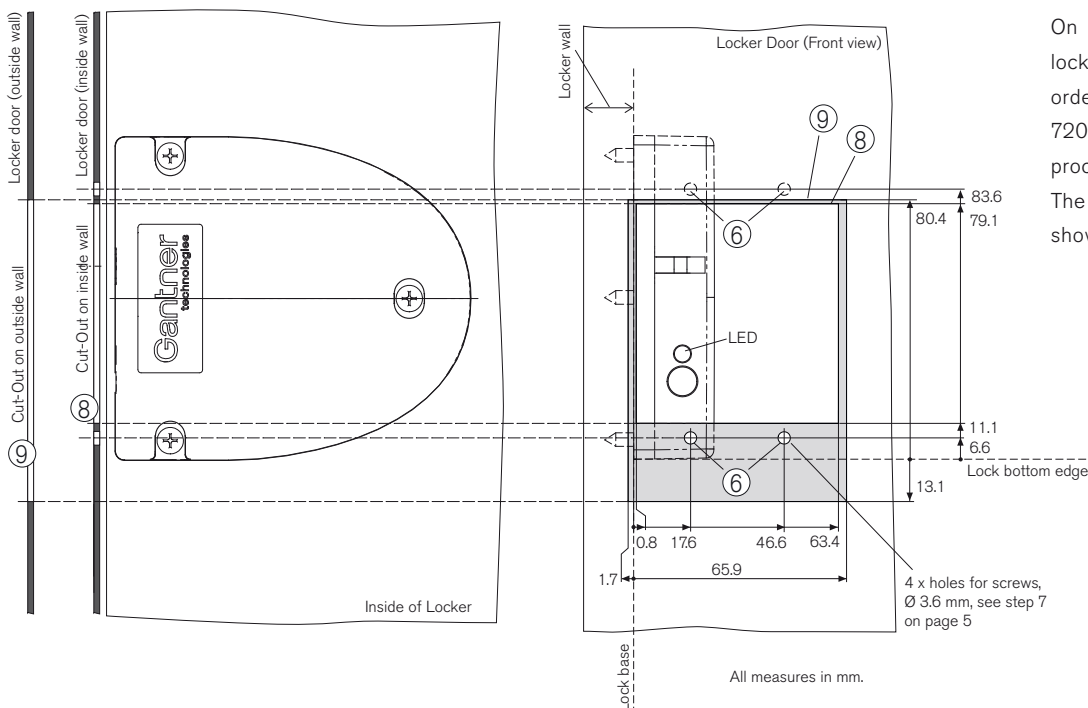

On the inside and outside walls of the locker door cut-outs must be made in order to mount the GAT NET.Lock Bolt Set 7200 and the label carrier. The mounting procedure is described on the next page. The measurements for the cut-outs are shown in the figure to the left.

Mounting procedure

Note: Before mounting all locks of the locker system a test installation of at least one lock and final function check must be performed like described below. Only if the tests are successful the rest of the locks may be mounted in the same way.

1. Drill the 3 holes (3) for the GAT NET.Lock 7000 into the locker wall.
2. Plug-in the connection cable (see page 6).
3. Mount the GAT NET.Lock 7000 with 3 screws (3) on the inside locker wall.

Note: Use the right screws according to the type of locker material.



Attention: The max. allowed tightening torque of the screws is 2 Nm.

4. On the inner wall of the locker door make the cut-out (62.6 x 68 mm) for the GAT NET.Lock Bolt Set 7200.
5. On the inner wall of the locker door drill the 4 holes (6) for mounting the GAT NET.Lock Bolt Set 7200.
6. On the outer wall of the locker door make the cut-out (67.6 x 93.5 mm) for the label carrier.
7. Mount the bolt set onto the inside wall of the locker door by using 4 screws as shown in the figure on the previous page.

Note: Only use Torx pan-head metal screws, Ø 3.5 mm, length 9.5 mm.



Attention: The max. allowed tightening torque of the screws is 2 Nm.

8. Push the label carrier onto the outside wall of the locker door. The label carrier will hold in place with the lashes on the label carrier. No screws are required.
9. Stick the front label (11) onto the label carrier.

Note: A customer-specific front label can be used to cover the LED hole. A transparent field should be placed on the label to show the LED light.

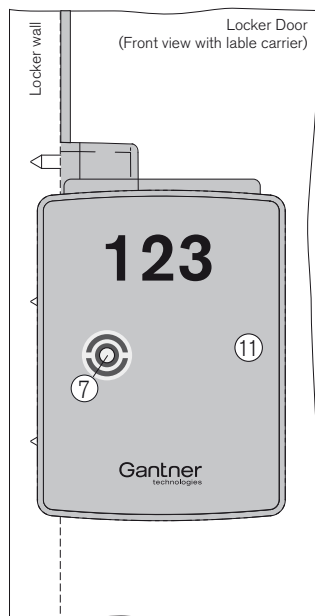

10. Close the door to test, if the locker door can be closed easily and if the door shackle inserts into the opening of the GAT NET.Lock 7000.

Electrical Connection

GAT NET.Lock 7000 Back Side

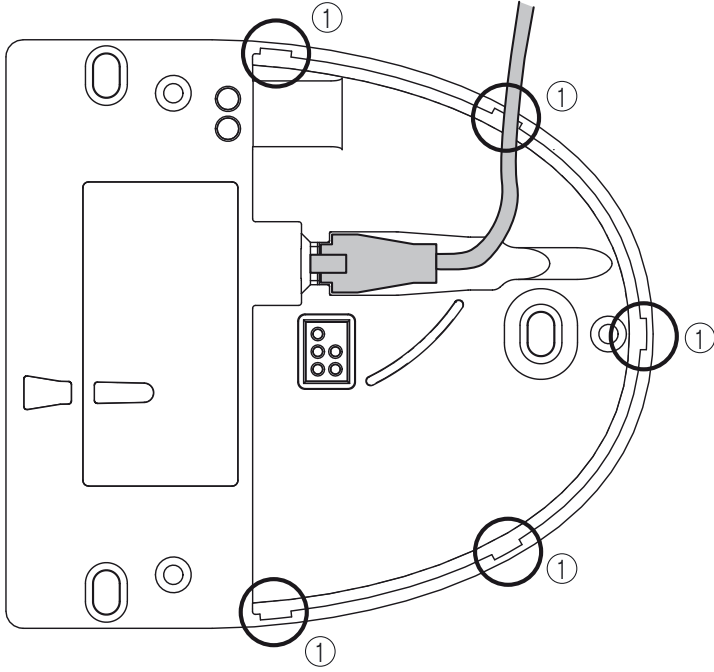

Connection Cable

To connect the GAT NET.Lock 7000 to a GAT NET.Controller S 7000 use the GAT NET.Lock Cable with 4-pin MOLEX plug on both ends. It is possible to connect 2 of these cables by using a GAT NET.Lock Connector (see order information).



To connect a GAT NET.Lock 7000 only an original cable from GANTNER Electronic GmbH may be used.

Power Supply and Signal Lines

DC power supply (see technical data) for unlocking and for the RFID reading field.

Antenna Adjustment

The GAT NET.Lock 7000 can automatically adjust the RFID antenna. A description can be found in the manual of the GAT NET.Lock 7000.

Cable Outlets

Cut-out one of these outlets (1) in order to feed the cable out of the housing.

Configuration

The configuration of the GAT NET.Lock 7000 and the controllers, where the GAT NET.Lock 7000 is connected, is done via the GAT Relaxx PC software. The configuration is described in the GAT NET.Lock 7000 and the GAT Relaxx manuals.

Safety instructions



- This device must be installed by qualified personnel only.
- The applicable safety and accident prevention regulations must be observed.

- Safety devices must not be removed.

- Please observe the technical data of the device specified on the data sheet.



- The device must be disconnected from the power supply prior to installation, assembly or dismantling.