

PERFORMANCE, DURABILITY, AFFORDABILITY... PLUS SUPERIOR HIGH LOADING CAPABILITY

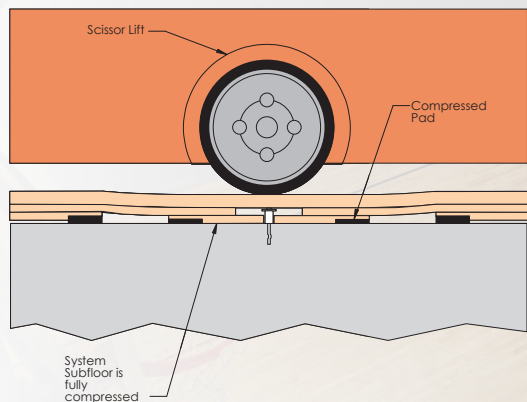

View of heavy load equipment on Eclipse SB floor system. Shows self blocking compression of Bio-Pad to prevent damage to the floor.

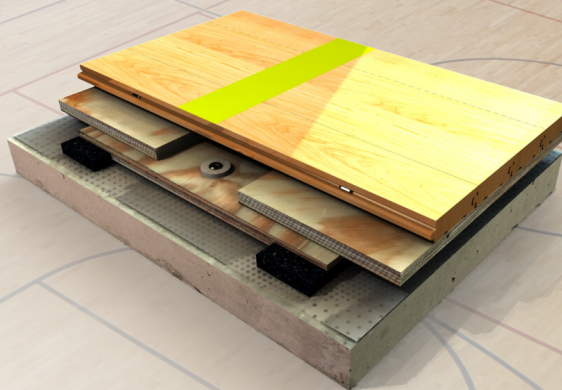

First *Eclipse*, now *Eclipse SB*, the **FIRST**, and **ONLY**, sports floors to be 3rd party certified to exceed all industry standards worldwide. From MFMA's PUR standard to EN 14904 Type 4, all the major sports flooring standards share a common vision:

- Safeguard the well-being of the athlete
- Ensure good game play performance
- Provide good structural integrity
- Anchored for dimensional stability and uniformity for long-term superior game play



Robbins pioneered the use of DIN in North America more than 20 years ago and continues to be the industry leader with more than 25 patents and numerous floor system innovations in use every day. Robbins latest design, *Eclipse SB*, was built to be a **COMPETITION CLASS FLOOR** that delivers outstanding bio-mechanic response and game play performance. It withstands the rigors of every-day use, while also handling heavy rolling loads such as bleachers, portable basketball goals, and heavy equipment. And to top it off, we also designed it to be **AFFORDABLE**. Only Robbins could pack this much performance into a single system!



So whether you're in charge of an elite NBA, NCAA or high school program, or just looking for the best value for your money at any level of play, you owe it to yourself to take a look at what *Eclipse SB* has to offer.

robbinsfloor.com | 1.800.543.1913

Product Specifications

System Type	Anchored Resilient Panel
Slab Depression	2" (51 mm) with 25/32" (20 mm) Maple
Surface- MFMA Northern Hard Maple	Robbins Continuous Strip [®] XL (FJ)
Exceeds Industry Standards for both Anchored & Floating:	<p>MFMA PUR DIN 18032 part 2 2001 DIN 18032 part 2 1991 ASTM F2772-09 FIBA Level 1 EN 14904 Type 4</p>
LEED Contributions	<p>MR credit 4, 5, & 7 IEQ 4.1, 4.2, 4.3, 4.4 FSC[®] Lumber Available <i>*Credits are based on products selected and location of facility</i></p>
Anchorage	Standard Drilled Anchor Pin/ Anti-Squeak Sleeve
Subfloor Construction	Double layer Plywood Nominal 1" Subfloor
Resilience Layer	Bio-Sport II Pad
Optional Construction	Contact a Robbins Representative for Alternative Systems
Warranty	1 year Industry Standard with optional Extended Warranty Program (<i>Egis Floorlife</i>)



Wall View

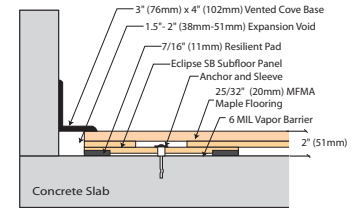

Threshold View

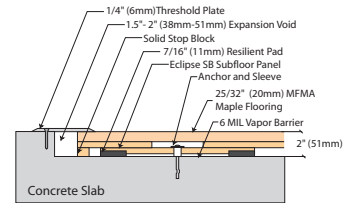

Equipment View

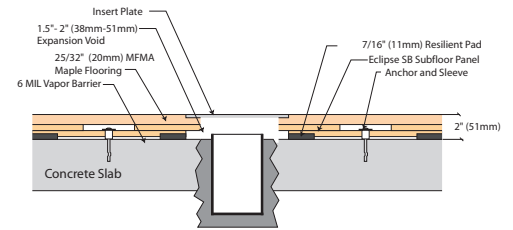

Reference Facilities

Montour Athletic Center
McKees Rocks, PA - 7,520 SF

Indian River State College
Ft. Pierce, FL - 11,000 SF

Churchville-Chili CSD
Churchville, NY - 12,220 SF

Wells Fieldhouse
Ft. Belvoir, VA - 20,271 SF

