

# ECLIPSE<sup>®</sup> SB (FLOATING)

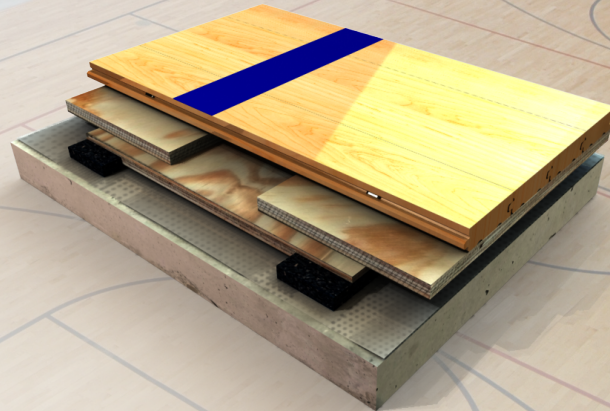

PERFORMANCE, DURABILITY, AFFORDABILITY...  
PLUS SUPERIOR HIGH LOADING CAPABILITY

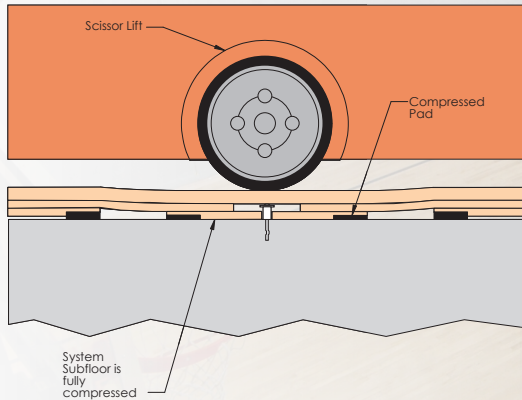

View of heavy load equipment on Eclipse SB floor system. Shows self blocking compression of Bio-Pad to prevent damage to the floor.

First *Eclipse*, now *Eclipse SB*, the **FIRST**, and **ONLY**, sports floors to be 3<sup>rd</sup> party certified to exceed all industry standards worldwide. From MFMA's PUR standard to EN 14904 Type 4, all the major sports flooring standards share a common vision:

- 🎯 Safeguard the well-being of the athlete
- 🎯 Ensure good game play performance
- 🎯 Provide good structural integrity



Robbins pioneered the use of DIN in North America more than 20 years ago and continues to be the industry leader with more than 25 patents and numerous floor system innovations in use every day. Robbins latest design, *Eclipse SB*, was built to be a **COMPETITION CLASS FLOOR** that delivers outstanding biomechanic response and game play performance. It withstands the rigors of every-day use, while also handling heavy rolling loads such as bleachers, portable basketball goals, and heavy equipment. And to top it off, we also designed it to be **AFFORDABLE**. Only Robbins could pack this much performance into a single system!



So whether you're in charge of an elite NBA, NCAA or high school program, or just looking for the best value for your money at any level of play, you owe it to yourself to take a look at what *Eclipse SB* has to offer.

robbinsfloor.com | 1.800.543.1913

Robbins, Inc. | 4777 Eastern Avenue | Cincinnati, OH 45226

MAPLE FLOORING SYSTEMS

## Product Specifications

System Type	Floating Panel
Slab Depression	2" (51 mm) with 25/32" (20 mm) Maple
Surface- MFMA Northern Hard Maple	Robbins Continuous Strip <sup>®</sup> XL (FJ)
Exceeds Industry Standards for both Anchored & Floating:	MFMA PUR DIN 18032 part 2 2001 DIN 18032 part 2 1991 ASTM F2772-09 FIBA Level 1 EN 14904 Type 4



LEED Contributions	MR credit 4, 5, & 7 IEQ 4.1, 4.2, 4.3, 4.4 FSC <sup>®</sup> Lumber Available <i>*Credits are based on products selected and location of facility</i>
--------------------	---



Subfloor Construction	Double layer Plywood Nominal 1" Subfloor
Resilience Layer	Bio-Sport II Pad
Optional Construction	Contact a Robbins Representative for Alternative Systems
Warranty	1 year Industry Standard with optional Extended Warranty Program ( <i>Egis Floorlife</i> )



Wall View

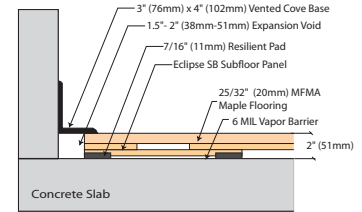

Threshold View

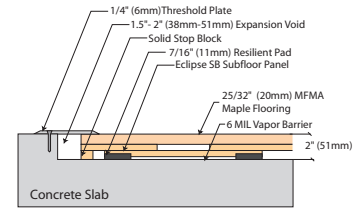

Equipment View

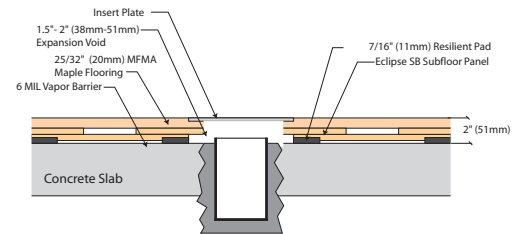

### Eclipse Family Reference Facilities

South Bend Charter School,  
South Bend, IN - 8,145 SF

Regis Sacred Heart  
Houston, TX - 7,665 SF

Bishop Chatard High School  
Indianapolis, IN - 10,002 SF

*\*All reference facilities are anchored systems*



robbinsfloor.com | 1.800.543.1913